

230

RFC/PG/1382

RAJASTHAN FINANCIAL CORPORATION

Udyog Bhawan, Tilak Marg,
Jaipur-302005
(Technical Cell)

Ref: RFC/MTC(81)/ 226

Dated : 15.06.2011

CIRCULAR

Sub : Revision in Building Construction rates for appraisal of loan cases and valuation of buildings.

At present, the Corporation is considering building construction rates for loan appraisal based on Standing Order X-3/2006 of PWD dated 24.4.2006 and the circular about revision of building construction rates was issued on 15.5.2006 (PG Circular No.1150).

The Standing Order X-3 of PWD have not been revised after 2006, therefore, looking to the persistent demand from loanees, and long time gap it has now been decided that Corporation will consider the revised construction rates calculated on the basis of latest BSR of PWD (2009) for appraisal & valuation of the buildings. The revised rates are given at Annexure-A. The building construction rates for Hotels, Multipurpose commercial complexes & residential complexes have already been revised and circulated vide PG Circular No.1278 dated 24.08.2009.

It is further clarified that the buildings which are not included, the rates of same may be considered on the basis of latest BSR issued by PWD.

Accordingly, Schedule 1/7 of LAS in PG may be replaced by the new schedule as per Annexure-A. The revision in rate will be effective with immediate effect.

(Pradeep Sen)
Chairman & Managing Director.

Encl. : As above.

C.C. to :-

1. Standard circulation at HO.
2. All BOs/SOs.
3. The DGM(WZ), A&I, Ajmer / Jodhpur.

Annexure 'A'
Schedule 1/7

S.NO.	Particulars	Specification	Rate
1	Factory Shed Ht.15 ft. closed in 4 sides.	Excavation in ordinary soil, stone masonry in foundation, stone/brick masonry in cement mortar in walls/super structure, RCC column, Plinth & lintel RCC beam, walls duly plastered & white wash, GI/AC sheet roofing supported over angular/tubular trusses & purling, CC flooring, wooden/iron joinery, electrification complete in all respect.	Rs.400/- per sq.ft.
2	Office Block ground floor without basement ht.11 ft.	Excavation in ordinary soil, stone masonry in foundation, stone/brick masonry in cement mortar in walls/super structure, RCC roofing, walls duly plastered, white wash, CC flooring, wooden/iron joinery, electrification, sanitary fitting, complete in all respect.	Rs.600/- per sq.ft.
3	Compound Wall one meter height above ground level. Add	Stone/brick masonry in lime/cement, mortar, walls duly plastered. For extra one ft. height beyond above.	Rs.470/- per rft. Rs.50/- per rft.

Provision of 10% contingencies is to be provided to meet out the expenses of unforeseen items and price escalation, if any.

0.1.1

Rajasthan Financial corporation											
Estimate of Boundry wall Based on BSR2009											
Assumption: Size		height 1 mtr. Above ground level									
S.No.	Particulars	Nos.	Quantity in Ft.			Volume/Area		Unit	Rate	Amount	
			L	B	H						
1	Excavation in ordinary soil All type for wall	1	1	3	3.5	10.5	0.30	Cu.mtr.	84	25.00	
2	P.C.C (1:5:10) in walls	1	1	3	0.5	1.5	0.04	Cu.mtr.	1625	69.09	
3	Stone masonry in walls in foundation in cement mortar (1:6)	1	1	2.5	1	2.5	0.07	Cu.mtr.	1410	99.91	
4	Stone masonry in walls in foundation in cement mortar (1:6)	1	1	1.5	1	1.5	0.04	Cu.mtr.	1410	59.95	
5	Stone masonry in wal in cement mortar (1:6)above G.L. and upto plinth	1	1	1	1	1	0.03	Cu.mtr.	1410	39.97	
6	Brick Masonry in walls 9"thick	1	1	0.75	3.28	2.46	0.07	Cu.mtr.	1972	137.50	
7	20 mm thick plaster in walls inside in cement mortar (1:6)	1	1		3.28	3.28	0.30	Sq.mtr	72	21.95	
8	12mm thick plaster in walls inside in cement mortar (1:6)	1	1		3.28	3.28	0.30	Sq.mtr	57	17.38	
Total										470.75	

Say Rs 470/- per ft

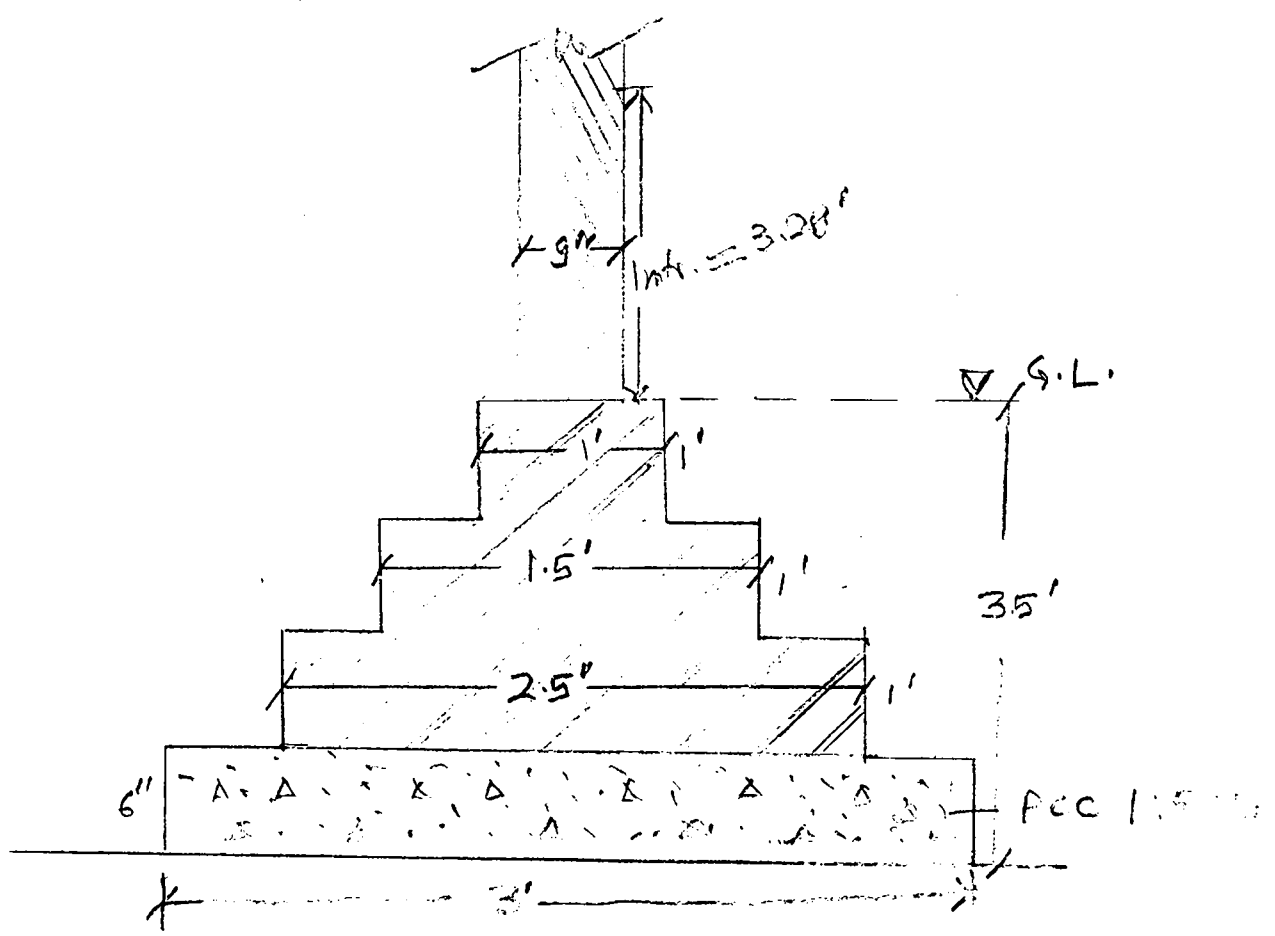

Section of B. Wall.